



■ Some of the photos may include optional equipment.

HYUNDAI MATERIAL HANDLING **Applied Tier 4 Engine**

25/30/33L-7A



PLEASE CONTACT

www.hyundai-mh.com

2020. 03 Rev 10



MOVING YOU FURTHER

NEW criteria of Forklift Trucks

Hyundai introduces a new line of 7A series
LPG forklift trucks.
Excellent power and performance make your
business more profitable.



OPSS (Operator Presence Sensing System)

Control of mast tilting, lifting and lowering is not possible through operation of the appropriate control when the operator is not in the seated position. (Option)

■ Some of the photos may include optional equipment.

The new master on the job-site!

Smooth running, efficient and ergonomically designed, 25/30/33L-7A are made to meet your needs.

44kW/2,300rpm



Powerful Engine HMC L4KB(2.4L) Engine

Market approved quality of HMC L4KB engine ensures incomparable performance, durability and additional value to the machine. Powerful and efficient engine provides excellent fuel consumption and excellent torque improved operator's comfort.
(EPA/CARB Tier-IV Certified)

Fast and Stable Performance

Being able to quickly raise and lower the mast, as well as tilt it forward and backward, provides the best operational conditions during unloading.

When the truck is fully loaded, mast lowering speed is carefully controlled to ensure safety by the down control valve.

Mast(Lift and Tilt) Look System. (Option)



Some of the photos may include optional equipment.

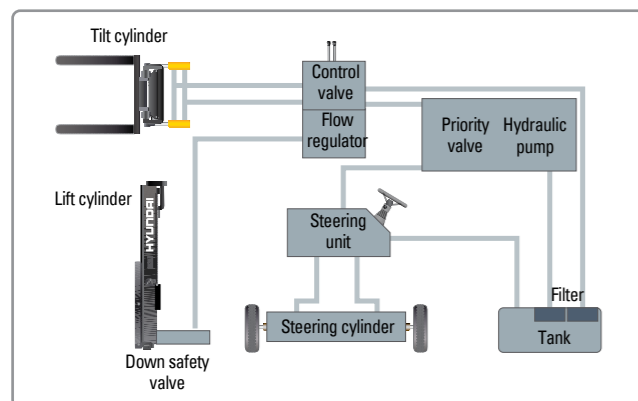

State-of-the-art Hydraulic System

The latest large-capacity hydraulic system reacts quickly during operation, and a low-noise control valve increases both efficiency and durability.



Fully Hydrostatic Power Steering

A hydraulic steering system always guarantees smooth and flexible steering, preventing overrun and kick-back.



Increased Mast Tilting Angle

Utilizing the mast tilting angle of 6 degrees forward and 10 degrees backward, the operator can safely and rapidly perform loading and unloading jobs.

Faster Travel Speed & Better Gradability

The powerful high-output engine provides greater acceleration, better gradability and faster travel speed on any tough terrains or slopes.



Gradability(Loaded)

25L-7A : 20.4°
30L-7A : 16.6°
33L-7A : 15.4°

Travel Speed(Unloaded)

25L-7A : 17.7 km/h
30L-7A : 18.6 km/h
33L-7A : 18.6 km/h

Ergonomic operator friendly compartment design!

A design based on human engineering relieves fatigue and increases operator's efficiency.

Operator Friendly Gauges and Water-resistant Monitor Panel

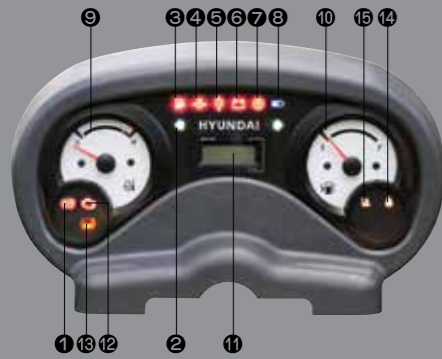

- 1 Parking brake lamp
- 2 Directional indicators
- 3 Fuel warning lamp
- 4 Engine oil warning lamp
- 5 Transmission oil temperature warning lamp
- 6 Battery charging warning lamp
- 7 Air cleaner filter warning light
- 8 Working light indicator
- 9 Water temperature gauge
- 10 Fuel gauge
- 11 Hour meter
- 12 Engine check lamp
- 13 Brake oil warning lamp
- 14 Seat belt warning
- 15 OPS warning



New High Visibility for Safe Operation

The operator is able to work with increased safety and accuracy due to a wider view mast.

Full suspension seat



An attractive and adjustable seat, based on a human engineering design, provides great comfort, safety and durability.

Grammer Seat (Option)



- Quick Achievement of the Ergonomically Best Sitting Position
- Asymmetrical Backrest
- Movable Armrests
- Seat Heating
- Practical Document Box



Travel Speed Control System (Option)



- ← In-Door : Max. Travel Speed (5 ~ 16 km/h)
- ← Out-Door : Max Travel Speed (Max Vehicle Speed)

Some of the photos may include optional equipment.



Ergonomically Positioned Pedals

Based on human engineering, the accelerator, brake and inching pedals are optimally positioned for convenience while operating the equipment.



Cup Holder & Console Box

Additional storage spaces are located inside the operating space for operator's convenience.



Quick Response of Operating Control Levers

Only minimal operator's effort is required for precise, safe and productive control.



Adjustable Steering Wheel

Steering wheel with horn button can be adjusted by a lever on the right-hand side for the most comfortable operator position.



Easy and Safe Shift Lever

A single lever on the left side of the steering column gives the operator fast, easy control of direction. The lever must be in the neutral position before the engine can be started.



Secondary Horn

Secondary Horn gives access to lights and horn

Danger-free through high durability!

Safety and durability are priorities in design of the equipment.



Strong Overhead Guard

The safety overhead guard meets ISO 6055 regulation and protects the operator during hazardous jobs.



Parking Brake

Ratchet type parking brake requires less effort from the operator to set.



■ Some of the photos may include optional equipment.

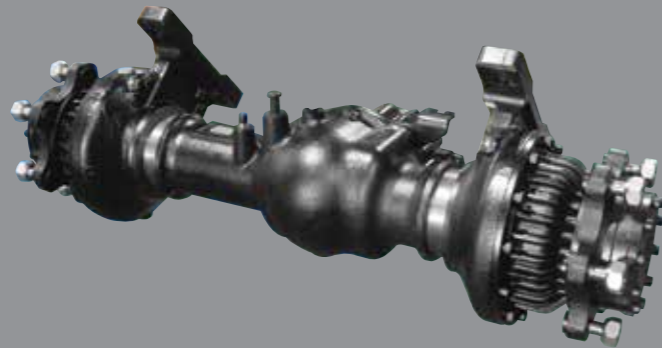

Highly Durable Split Type Drive Axle

The bevel gear set and hub reduction axle smoothly delivers desired torque to the drive wheels.



Large Footboard & Hand Grip

Wide "open" step offers convenience and safety when entering and exiting truck.



Expansion Bellows

The expansion bellows absorbs vibration and reduces noise generated from the exhaust gas system and also extends the life cycle of exhaust gas system.



Electrically Monitored Air Filter

Air cleaner sensor alerts the operator of a restricted air filter and allows replacement before damage.

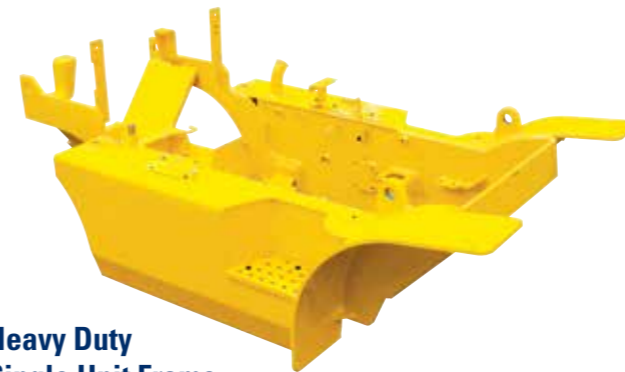

Heavy Duty Single Unit Frame

Heavy duty single unit type frame, designed on the basis of accurate structural analysis, guarantees durability and safety.



Bright, Protected Headlights

Bright, Protected head lights are positioned for exceptional visibility.

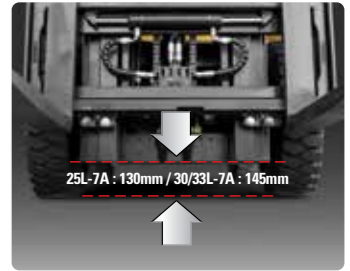

Ground Clearance

The engine and transmission are assembled horizontally and positioned high in the frame to protect major components during operation on rugged surface.

25L-7A : 130mm / 30/33L-7A : 145mm

Mast Specification - 30L-7A

Mast Type	Maximum Fork Height		Overall Height Lowered		FREE LIFT						Tilt Angle		Load capacity w/o integral side shift								TRUCK WEIGHT UNLOAD							
					with bkr		w/o bkr		w/o bkr (3/4-SPOOL)				Single Tire		Double Tire		Single Tire		Double Tire		Single Tire		Double Tire					
	in	mm	in	mm	in	mm	in	mm	in	mm	deg	deg	24 in LC	500mm LC	24 in LC	500mm LC	24 in LC	500mm LC	24 in LC	500mm LC	lb	kg	lb	kg	lb	kg	lb	kg
	2-STAGE LIMITED FREE LIFT	V300	118.1	3000	80.3	2040	6.1	155	6.1	155	6.1	155	6	10	6000	3000	6000	3000	6000	3000	6000	3000	9205	4175	9555	4334		
+V330		129.9	3300	86.2	2190	6.1	155	6.1	155	6.1	155	6	10	6000	3000	6000	3000	6000	3000	6000	3000	9250	4196	9599	4354			
V350		137.8	3500	90.2	2290	6.1	155	6.1	155	6.1	155	6	10	6000	3000	6000	3000	6000	3000	6000	3000	9289	4213	9638	4372			
V370		145.7	3700	96.1	2440	6.1	155	6.1	155	6.1	155	6	10	6000	3000	6000	3000	6000	3000	6000	3000	9339	4236	9689	4395			
V400		157.4	4000	102.0	2590	6.1	155	6.1	155	6.1	155	6	10	6000	3000	6000	3000	5920	2950	6000	2975	9407	4267	9757	4426			
V430		169.3	4300	107.9	2740	6.1	155	6.1	155	6.1	155	6	6	5840	2925	6000	3000	5660	2875	6000	2925	9523	4320	9873	4478			
V450		177.2	4500	113.8	2890	6.1	155	6.1	155	6.1	155	6	6	5730	2875	6000	2950	5550	2825	5950	2875	9573	4342	9923	4501			
V470		185.0	4700	117.7	2990	6.1	155	6.1	155	6.1	155	6	6	5510	2825	5790	2925	5330	2750	5780	2825	9607	4358	9956	4516			
V500		196.9	5000	123.6	3140	6.1	155	6.1	155	6.1	155	6	6	4740	2775	5680	2850	4560	2700	5620	2775	9657	4380	10007	4539			
2-STAGE FULL	VF295	116.1	2950	80.3	2040	33.9	860	51.7	1314	51.7	1314	6	6	6000	3000	6000	3000	6000	3000	6000	3000	9294	4216	9643	4374			
	VF325	127.9	3250	86.2	2190	39.8	1010	57.6	1464	57.6	1464	6	6	6000	3000	6000	3000	6000	3000	6000	3000	9371	4251	9720	4409			
3-STAGE FULL FREE LIFT	TF370	145.7	3700	72.4	1840	26.0	660	43.9	1114	38.4	975	6	6	6000	3000	6000	3000	5950	2900	6060	2950	9535	4325	9884	4483			
	TF400	157.4	4000	76.4	1940	29.9	760	47.8	1214	42.3	1075	6	6	5840	2925	6000	3000	5780	2850	5890	2900	9589	4350	9937	4508			
	TF430	169.3	4300	80.3	2040	33.9	860	51.7	1314	46.3	1175	6	6	5730	2850	5880	2925	5670	2775	5780	2825	9638	4372	9986	4530			
	TF450	177.2	4500	84.3	2140	37.8	960	55.7	1414	52.2	1325	6	6	5660	2800	5760	2875	5560	2725	5670	2775	9694	4397	10042	4555			
	TF470	185.0	4700	86.2	2190	39.8	1010	57.6	1464	52.2	1325	6	6	5400	2775	5660	2825	5220	2675	5480	2725	9725	4411	10073	4569			
	TF500	196.9	5000	90.2	2290	43.7	1110	61.6	1564	56.1	1425	6	6	4630	2700	5510	2775	4450	2600	5330	2675	9774	4434	10123	4592			
	TF550	216.5	5500	98.0	2490	51.6	1310	69.4	1764	65.9	1675	6	6	3040	2600	5290	2675	2860	2525	5110	2575	9871	4478	10220	4636			
	TF600	236.2	6000	105.9	2690	59.4	1510	77.3	1964	73.8	1875	6	6	2020	1600	4630	2575	1840	1750	4450	2475	10026	4548	10374	4706			
	TS370	145.7	3700	72.4	1840	26.0	660	43.9	1114	41.5	1053	6	6	6000	3000	6000	3000	5950	2900	6060	2950	9535	4325	9884	4483			
	TS400	157.4	4000	76.4	1940	29.9	760	47.8	1214	45.4	1153	6	6	5840	2925	6000	3000	5780	2850	5890	2900	9589	4350	9937	4508			
	TS430	169.3	4300	80.3	2040	33.9	860	51.7	1314	49.3	1253	6	6	5730	2850	5880	2925	5670	2775	5780	2825	9638	4372	9986	4530			
	TS450	177.2	4500	84.3	2140	37.8	960	55.7	1414	55.2	1403	6	6	5660	2800	5760	2875	5560	2725	5670	2775	9694	4397	10042	4555			
	TS470	185.0	4700	86.2	2190	39.8	1010	57.6	1464	55.2	1403	6	6	5400	2775	5660	2825	5220	2675	5480	2725	9725	4411	10073	4569			
	TS500	196.9	5000	90.2	2290	43.7	1110	61.6	1564	59.2	1503	6	6	4630	2700	5510	2775	4450	2600	5330	2675	9774	4434	10123	4592			
	TS550	216.5	5500	98.0	2490	51.6	1310	69.4	1764	69.0	1753	6	6	3040	2600	5290	2675	2860	2525	5110	2575	9871	4478	10220	4636			
TS600	236.2	6000	105.9	2690	59.4	1510	77.3	1964	76.9	1953	6	6	2020	1600	4630	2575	1840	1750	4450	2475	10026	4548	10374	4706				
4-STAGE FULL FREE LIFT	QF610	240.7	6115	85.6	2175	37.6	955	57.0	1449	57.0	1449	3	3	3730	1800	4850	2350	3550	1710	4590	2220	10351	4695	10701	4854			
	QF660	260.4	6615	93.5	2375	47.0	1195	64.9	1649	64.9	1649	3	3	3530	1700	4520	2200	3350	1610	4280	2070	10483	4755	10833	4914			
	QF700	276.2	7015	97.4	2475	51.0	1295	68.9	1749	68.9	1749	3	3	3110	1500	4430	2150	2950	1420	4190	2020	10549	4785	10899	4944			
	QF745	293.9	7465	103.3	2625	56.9	1445	74.8	1899	69.4	1762	3	3	2510	1200	4230	2050	2360	1120	3990	1930	10650	4831	11001	4990			
	QF790	311.6	7915	109.3	2775	62.8	1595	75.4	1915	69.4	1762	3	3	1570	750	2290	1100	1430	680	2070	990	10873	4932	11224	5091			

* TS-Mast : Wide Visible 3 Stage Full Free Lift Mast with 2 Free Lift Cylinders.

Mast Specification - 33L-7A

Mast Type	Maximum Fork Height		Overall Height Lowered		FREE LIFT						Tilt Angle		Load capacity w/o integral side shift								TRUCK WEIGHT UNLOAD					
					with bkr		w/o bkr		w/o bkr (3/4-SPOOL)				Single Tire		Double Tire		Single Tire		Double Tire		Single Tire		Double Tire			
	in	mm	in	mm	in	mm	in	mm	deg	deg	24 in LC	500mm LC	24 in LC	500mm LC	24 in LC	500mm LC	24 in LC	500mm LC	24 in LC	500mm LC	lb	kg	lb	kg	lb	kg
	2-STAGE LIMITED FREE LIFT	V300	118.1	3000	83.1	2110	155	6.1	155	6.1	155	6.1	6	10	6500	3300	6500	3300	6500	3300	6500	3300	9733	4415	9947	4512
+V330		129.9	3300	89.0	2260	155	6.1	155	6.1	155	6.1	6	10	6500	3300	6500	3300	6500	3300	6500	3300	9785	4439	9999	4536	
V350		137.8	3500	92.9	2360	155	6.1	155	6.1	155	6.1	6	10	6500	3300	6500	3300	6500	3300	6500	3300	9820	4454	10034	4551	
V370		145.7	3700	98.8	2510	155	6.1	155	6.1	155	6.1	6	10	6500	3300	6500	3300	6500	3300	6500	3300	9872	4478	10086	4575	
V400		157.4	4000	104.7	2660	155	6.1	155	6.1	155	6.1	6	10	6500	3300	6500	3300	6500	3200	6500	3300	9943	4510	10157	4607	
V430		169.3	4300	110.6	2810	155	6.1	155	6.1	155	6.1	6	6	6500	3200	6500	3300	6500	3100	6500	3300	10061	4564	10275	4661	
V450		177.2	4500	116.5	2960	155	6.1	155	6.1	155	6.1	6	6	6500	3150	6500	3300	6500	3030	6500	3300	10113	4587	10327	4684	
V470		185.0	4700	120.5	3060	155	6.1	155	6.1	155	6.1	6	6	6500	3100	6500	3300	6500	3000	6500	3200	10148	4603	10362	4700	
V500		196.9	5000	126.4	3210	155	6.1	155	6.1	155	6.1	6	6	6500	3050	6500	3250	6460	2930	6500	3150	10200	4627	10414	4724	
2-STAGE FULL	VF295	116.1	2950	83.1	2110	930	36.6	1384	54.5	1384	54.5	6	6	6500	3300	6500	3300	6500	3300	6500	3300	9830	4459	10031	4550	
	VF325	127.9	3250	89.0	2260	1080	42.5	1534	60.4	1534	60.4	6	6	6500	3300	6500	3300	6500	3200	6500	3300	9908	4494	10109	4585	
3-STAGE FULL FREE LIFT	TF370	145.7	3700	74.4	1890	710	28.0	1069	42.1	1069	42.1	6	6	6500	3250	6500	3300	6500	3150	6500	3300	10144	4602	10345	4693	
	TF400	157.4	4000	78.3	1990	810	31.9	1169	46.0	1169	46.0	6	6	6500	3160	6500	3300	6500	3040	6500	3300	10193	4624	10394	4715	
	TF430	169.3	4300	82.3	2090	910	35.8	1269	50.0	1269	50.0	6	6	6500	3100	6500	3300	6500	3000	6500	3200	10239	4644	10440	4735	
	TF450	177.2	4500	86.2	2190	1010	39.8	1369	53.9	1369	53.9	6	6	6500	3030	6500	3250	6430	2920	6500	3150	10287	4666	10488	4757	
	TF470	185.0	4700	88.2	2240	1060	41.7	1419	55.9	1419	55.9	6	6	6500	3000	6500	3200	6390	2900	6500	3100	10317	4680	10517	4771	
	TF500	196.9	5000	92.1	2340	1160	45.7	1519	59.8	1519	59.8	6	6	6480	2940	6500	3125	6260	2840	6500	3030					

Load Capacity

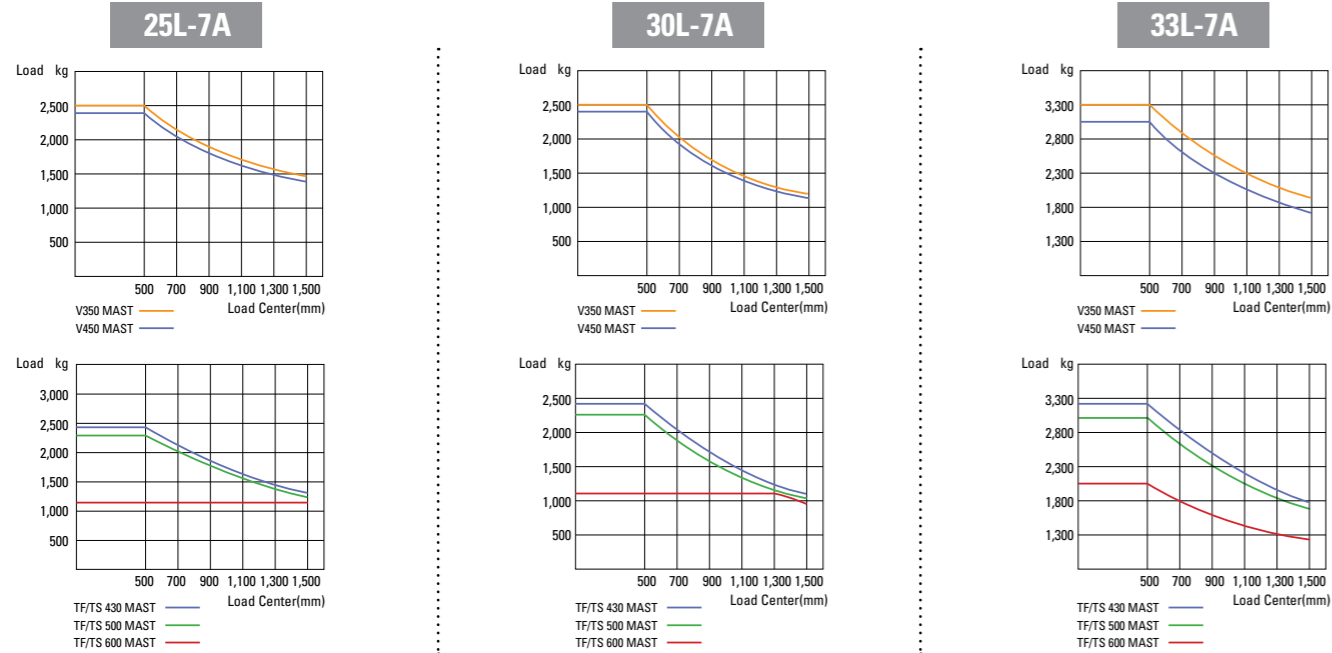

Optional Items

- CABIN & HEATER
- SIDE SHIFT / INTEGRAL SIDE SHIFT
- FORK (L x W x T) (mm)

25L-7A	900 x 100 x 45	1,000 x 100 x 45	1,050 x 100 x 45
	1,200 x 100 x 45	1,350 x 100 x 45	1,500 x 100 x 45
	1,650 x 100 x 45	1,800 x 100 x 45	
- 30/33L-7A

- 900 x 122 x 45
- 1,050 x 122 x 45
- 1,150 x 122 x 45
- 1,200 x 122 x 45
- 1,350 x 122 x 45
- 1,500 x 122 x 45
- 1,650 x 122 x 45
- 1,800 x 122 x 45
- 1,970 x 122 x 45
- 2,120 x 122 x 45
- 2,300 x 122 x 45
- 2,400 x 122 x 45
- TILTING : 6/6°, 3/3°
- TIRE : No-marking, Double
- SEAT : Pocket, Belt, Arm Rest, Hip Rest
- LPG TANK CLAMP : Swing Out, Swing Down

- M.C.V : 4-Spool
- ATTACH PIPING : 3 Spool-piping, 4 Spool-piping
- MASTER SWITCH / HAZARD SWITCH
- BEACON LAMP / WORK LAMP
- TRAVEL SPEED CONTROL SENSOR
- TS-MAST
- PRECLANER

Dimension

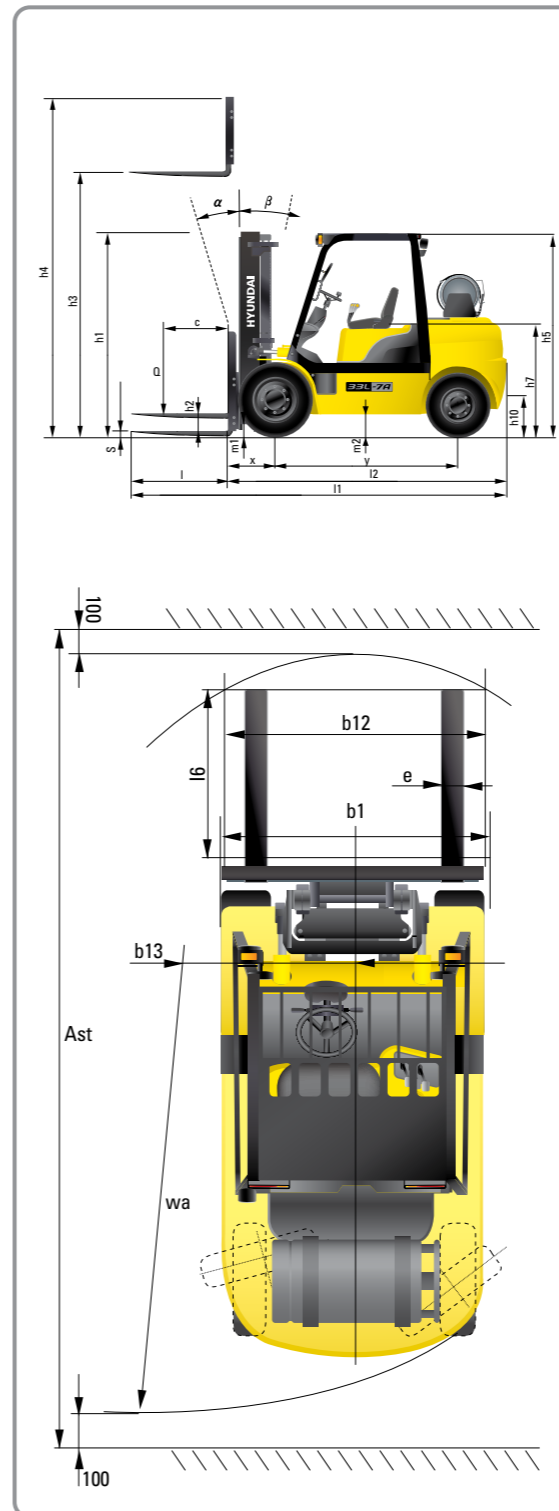

Specification

Identification			
1.1	Manufacturer	Hyundai	Hyundai
1.2	Manufacturer's type designation	25L-7A	30L-7A
1.3	Drive: electric (battery or mains),diesel,petrol,fuel gas,manual	LP	LP
1.4	Type of operation:hand,pedestrian,standing,seated,order-picker	seated	seated
1.5	Load capacity / rated load	Q (kg)	3,000
1.6	Load center distance	c (mm)	500
1.8	Load distance, center of drive axle to fork	x (mm)	468
1.9	Wheelbase	y (mm)	1,700
Weights			
2.1	Service weight	kg	3,706
2.2	Axle loading, loaded front/rear	kg	5,452 / 753
2.3	Axle loading, unloaded front/rear	kg	1,486 / 2,220
Wheels, Chassis			
3.1	Tires:solid rubber, superplastic, pneumatic, polyurethane	Pneumatic	Pneumatic
3.2	Tires size, front	7.00 - 12 - 12PR	8.15 x 15 - 14PR
3.3	Tires size, rear	6.50 - 10 - 12PR	6.50 - 10 - 12PR
3.5	Wheels, number front x rear (x = driven wheels)	2 x 2	2 x 2
3.6	Track width, front	b10 (mm)	965
3.7	Track width, rear	b11 (mm)	980
Basic Dimensions			
4.1	Mast / fork carriage tilt forward / backward(α / β)	degrees	6 / 10
4.2	Lowered mast height	h1 (mm)	2,175
4.3	Free lift	h2 (mm)	155
4.4	Lift height	h3 (mm)	3,300
4.5	Extended mast height	h4 (mm)	4,485
4.7	Overhead load guard (cab) height	h5 (mm)	2,180
4.8	Seat height / standing height	h7 (mm)	1,110
4.12	Coupling height	h10 (mm)	283
4.19	Overall length	l1 (mm)	3,644
4.20	Length to face of forks	l2 (mm)	2,594
4.21	Overall width	b1 (mm)	1,160
4.22	Fork dimensions	l / e / s (mm)	1,050 x 100 x 45
4.23	Fork carriage ISO 2328, class / type A,B	II / A	III / A
4.24	Fork-carriage width	b12 (mm)	1,102
4.31	Ground clearance, loaded, under mast	m1 (mm)	130
4.32	Ground clearance, centre of wheelbase	m2 (mm)	171
4.33	Aisle width for pallets 1000 x 1200 crossways	Ast (mm)	3,966
4.34	Aisle width for pallets 800 x 1200 lengthways	Ast (mm)	4,166
4.35	Turning radius	Wa (mm)	2,298
4.36	Smallest pivot point distance	b13 (mm)	714
Performance Data			
5.1	Travel speed, Unloaded	km/h	17.7
5.2	Lift speed, Loaded/Unloaded	mm/s	600 / 610
5.3	Lowering speed, Loaded/Unloaded	mm/s	500 / 450
5.5	Drawbar pull, Loaded	kg	2,412
5.7	Gradient performance, Loaded	%	37.1
5.9	Accelsration time, loaded/unloaded (10m)	sec	NA
5.10	Service brake		FOOT
Engine			
6.1	Engine manufacturer / type		HMC L4KB
6.2	Engine power acc. to ISO 1585 (gasoline)	kW	44 (35.7)
6.3	Rated speed	1/min	2,300
6.4	No. of cylinder / cubic capacity	/cm³	4 / 2,359
Other Details			
8.2	Type of drive control		Power Shift
8.3	Operating pressure	bar	220 / 165
8.4	Oil volume	ℓ	30
8.5	Noise	db(A)	80